

LEAPERS[®], INC.

USER MANUAL



USER MANUAL

RED/GREEN DOTS



**RANGE
ESTIMATING SCOPES**

**RETICLE
INTENSIFIED SCOPES**

TOTAL SOLUTION TO YOUR NEEDS

-COMMITMENT TO BEST QUALITY, BEST VALUE AND BEST SERVICE-

www.LEAPERS.com

32700 Capitol Street, Livonia, MI 48150, U.S.A.

Tel:(734)542-1500

Fax:(734)542-7095

Email:office@leapers.com

RED/GREEN DOTS

MODEL NO.:
SCP-DS3068W

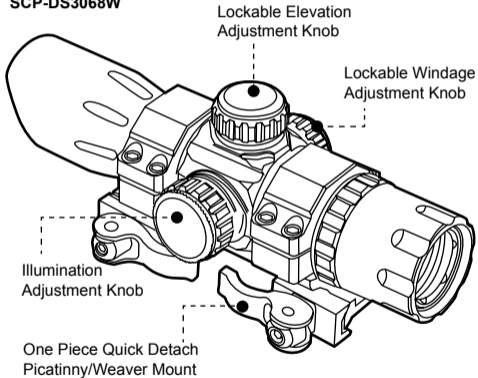

MODEL NO.:
SCP-DS3840W

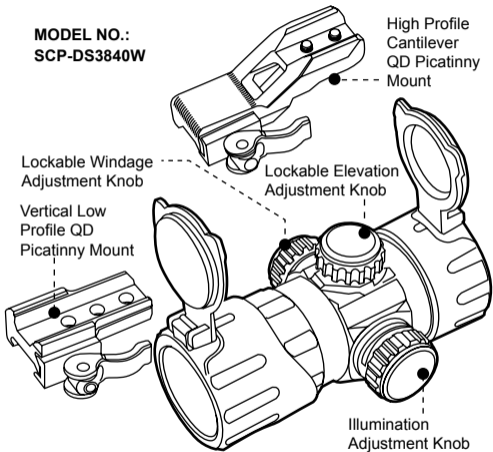

MODEL NO.:
SCP-DS3039W

Vertical Low
Profile QD
Picatinny
Mount

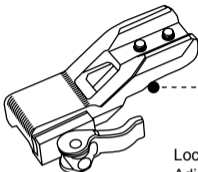

High Profile
Cantilever
QD Picatinny
Mount

Lockable Elevation
Adjustment Knob

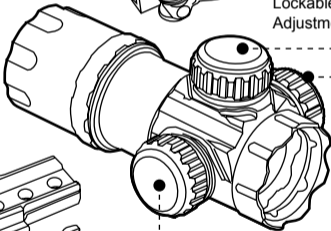

Illumination
Adjustment
Knob

Lockable Windage Adjustment Knob

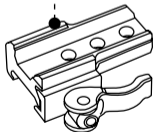

MODEL NO.:
SCP-DS3028W

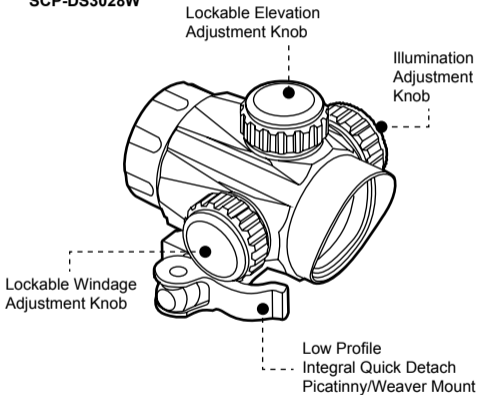

MODEL NO.:
SCP-DS3026W

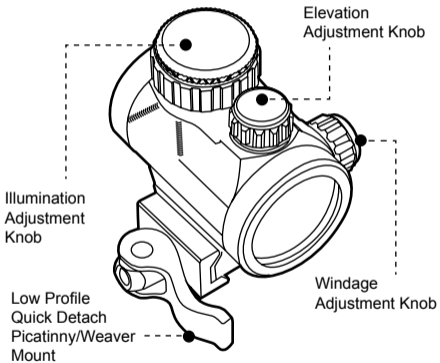

MODEL NO.:
SCP-RG40CDQ
SCP-RG40SDQ

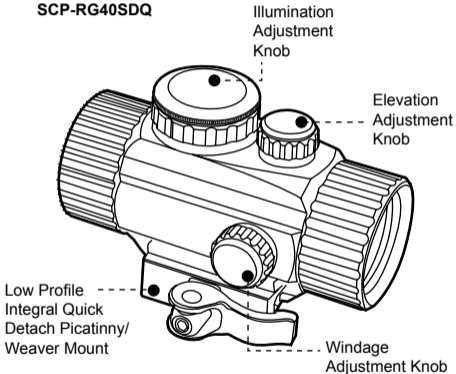

MODEL NO.:
SCP-RD40RGW-A

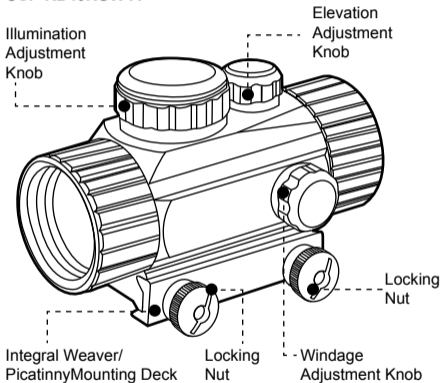

A. Install QD Mounts

(for SCP-DS3840W and SCP-DS3039W only)

1. Both units come with a high profile cantilever QD mount and a vertical low profile QD mount. Hold the dot sight over your rifle at your natural shooting position to estimate the ideal height and determine which mount fits best.
2. The high profile mount has 2 holes while the low profile mount has 3 holes. Both mounts can be used bi-directionally. The extra hole and the bi-directional feature allow the user flexibility in installation to achieve optimal eye relief. To install, locate two set screws and put a spring washer onto each screw. Based on your eye relief preference, select

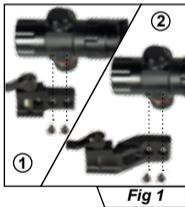

two holes on the QD mount, fit the mount against the mating base on the dot sight, and align the mount holes with the dot sight holes. Install and fasten the set screws to fully secure the mount as shown in **Fig 1**.

B1. Install the Dot Sight onto the Rifle: (for Dot Sights with QD Mounts)

1. Hold the rifle in your natural shooting position. Place the scope onto the Picatinny rail on the rifle to estimate the best position for your shooting preference. Then set the rifle at a steadying device.
2. **CAUTION:** For SCP-DS3840W, SCP-DS3039W and SCP-DS3020W, always double check to ensure that screws attaching the mounting base to the scope body are securely tightened before shooting.

3. Turn the Cam Lever toward its unlocked position as shown in **Fig 2**. Place the QD mount on the Picatinny Rail at the desired position. Make sure to seat the cross bolt into a selected slot. Note: For SCP-DS3068W, turn the locking levers toward opposite directions to unlock as shown in **Fig 3**.

**Fig 2****Fig 3**

4. Turn the Cam Lever toward the locking position to begin locking the QD mount on the rail, but do not complete the locking motion, leaving some travel distance to allow for adjustment.

5. Use the included Allen wrench to adjust the Hex Screw at the side of the cam for proper tension and fit against the rail. Adjust clockwise to increase the tension and tighten the clamping width. Adjust counter-clockwise to decrease the tension and increase the clamping width.
6. The optimal tension is achieved when the side plate first makes contact with the Picatinny rail while the Cam Lever still has enough travel left for you to securely snap into its locking position. Once you achieve the optimal tension, push the Cam Lever all the way for a positive lock onto the rail. You may repeat Step 3 and 4 if needed to find the best clamping tension and locking position for your mount. This process adapts the mount to your specific rail.

B2. Install the Dot Sight onto the Rifle: (for Dot Sights with Locking Nuts)

1. Place the mounting deck onto the rail.
2. Adjust the mounting deck position until you are satisfied with the view.
3. Tighten each locking nut with a screwdriver or coin as shown in **Fig. 4**.



Fig 4

C. Install Battery:

1. The battery is housed inside the Red/Green Illumination Rheostat. **Fig. 5** shows

SCP-RD40RGW-A and **Fig. 6** shows all other models.

2. Firmly hold the housing of the Rheostat with 2 fingers.



Fig 5

3. Use your other hand to open the battery compartment by unscrewing the top cap.



Fig 6

4. Remove the battery (if there is one) and install a new one.
5. Replace the cap and screw it clockwise to tighten.

D. On/Off Switch and Brightness Adjustment:

1. Dial the rheostat to turn on the illumination.
2. For SCP-RD40RGW-A, the white dot on the left side

of the sight indicates the current setting as shown in **Fig. 7**. When the Current Setting is “R” or “G”, the unit is off.

3. Red/Green colored coded numbers (**Fig. 7**) or the red/green band (**Fig. 8**) indicates the brightness of the illumination.
4. Select the color illumination and adjust to the desired brightness.
5. To conserve battery life, always turn off when not in use.

Fig 7**Fig 8**

E. Zero the Dot Sight:

Note: Leapers dot sight comes with two different adjustment turrets -

Lockable Target Turrets (**Fig. 9**)

Compact Turrets (**Fig. 10**)

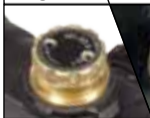
Fig 9**Fig 10**

The purpose of zeroing the dot sight is to ensure that the illuminated dot is aligned with the impact point of your rifle. Before zeroing, read the following adjustment knob instruction carefully.

1. For Compact Turrets, use a flat head screwdriver to adjust the windage and elevation as shown in **Fig. 11**. For models with Compact Turrets, skip Section 2 ZERO LOCKING.

**Fig 11**

2. ZERO LOCKING - For models that comes Lockable Target Turrets as in **Fig. 9**, the Windage and Elevation Adjustment Knobs have a unique zero locking feature. You have the option to lock down once it's zeroed.

1. Unscrew and remove the cap of the adjustment knob. Both windage and elevatoin knobs were set to the Locked Position at the factory. Gently dial the knob and test if it is locked. If not, you can skip section II.

**Fig 12**

- II. To Unlock: Locate the two locking screws shown in **Fig. 12**. Use the included small Allen wrench to unlock both locking screws by turning them counterclockwise 1/4 revolution.

WARNING:

DO NOT over-loosen the locking screws! It may cause the face cover to fall off if screws are backed out too far. If, by mistake, the face lid fell off when you are looseing the screws, please follow instructions below to replace the face cover.

- A. Lock both screws down, making sure that they are flush with the surface.
- B. Apply a little loctite or similar adhesive on the flat surface of the knob. Make sure that no adhesive gets into the screw holes or onto the screws.
- C. Carefully place the face cover back on the knob and align with the locking holes properly. Firmly press the face cover to achieve full contact and wait a few seconds to let the cover adhere to the flat surface of the knob.

- III. To Lock: Use the included small Allen wrench to fully lock down both screws by turning them clockwise. It is recommended that you gradually lock both screws alternately until they are fully and evenly locked.
3. ZEROING - For models with Lockable Target Turrets, unlock the target turret to allow for adjustment. For models with compact turrets, make sure to have a flat head screwdriver ready for adjustment.
 - I. Zeroing with a Bore Sighter
 - A. When the turret is ready for adjustment, you will be able to dial and have a clear audible click.
 - B. Follow the instruction of your bore sighter and install it in the muzzle of your rifle, lining it with the dot sight as closely as possible.
 - C. Turn on the illumination and set it at your preferred color and brightness.
 - D. Sighting through the dot sight as though you

were going to shoot and dial the knobs to make adjustment for the elevation and/or windage until the crosshair matches the bore sighter.

- II. Zeroing on a Target
 - A. Place a target 100 yards away (35 yards for air gun).
 - B. Use a steadying device such as a shooting stand or bipod, set the illumination to your prefer settings, aim at the center of the target and fire a test group shot, if safe to do so.
 - C. If the impact point of the test shot is exactly in the center of the target then the dot sight is zeroed. If not, you will need to adjust the reticle using the elevation and/or windage adjustment. Follow the Point of Impact (POI) direction on the turret to dial the knob accordingly.
 - D. Having adjusted the elevation and windage as required, fire, if safe to do so, another test group. Keep adjusting and test firing until the

test shot hit the target center in an acceptable small grouping.

- E. Now the dot sight should be zeroed. Make sure to lock both elevation and windage knobs.

F. Different Dot Sight Reticles:

Note: Depending on your models, your dot sight may come with one of the following reticles:

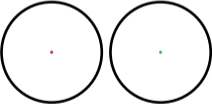
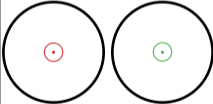
	Single Dot Reticle	Circle Dot Reticle
Illustration		
Specs	Dot size: 4 MOA	Dot size: 4 MOA Circle Dia.: 60MOA

G. Care and Maintenance:

1. Take care not to drop or knock the dot sight once it is zeroed.
2. Maintain the metal surface of the dot sight by removing any dirt or sand with a soft brush so as to avoid scratching the finish.
3. Wipe the lens with a clean flannel cloth to keep it clean and dry. In order to avoid scratching the glass, ensure both the lens and cloth are clean. Do not use finger or finger nail to touch/clean lenses.
4. Store the dot sight in a cool dry place when not in use. Be careful to avoid contact with acid, alkaline or corrosive chemicals.
5. Do not attempt to lubricate any part of the dot sight.
6. Do not disassemble the dot sight. Do not loosen or remove screws or parts. Any such or similar actions will void the warranty.

CAUTION: Viewing the sun can cause serious eye injury. Never look directly into the sun with this or any optics.

H. Two Year Manufacturer's Warranty

Warranty against material or workmanship defects applies based on the following conditions -

1. Product is a first-hand purchase. Evidence of purchase is required for warranty service. Warranty is not transferrable.
2. Product is not disassembled, parts/ screws not removed or loosened, and the product is not tampered with in any way. Any evidence of such interference will void the warranty.
3. Product has not been abused, maliciously damaged or treated in a manner not in keeping with the purpose it is designed for.

For warranty service, please contact the scope distributor and provide a written problem description to obtain a Return Authorization Number before returning the product for repair or replacement.



**32700 Capitol Street,
Livonia, MI 48150, U.S.A.**

Tel:(734)542-1500

Fax:(734)542-7095

Email:office@leapers.com

WWW.LEAPERS.COM

**Explore
More
At**